

ELECON DOUBLE REDUCTION WORM GEAR UNITS

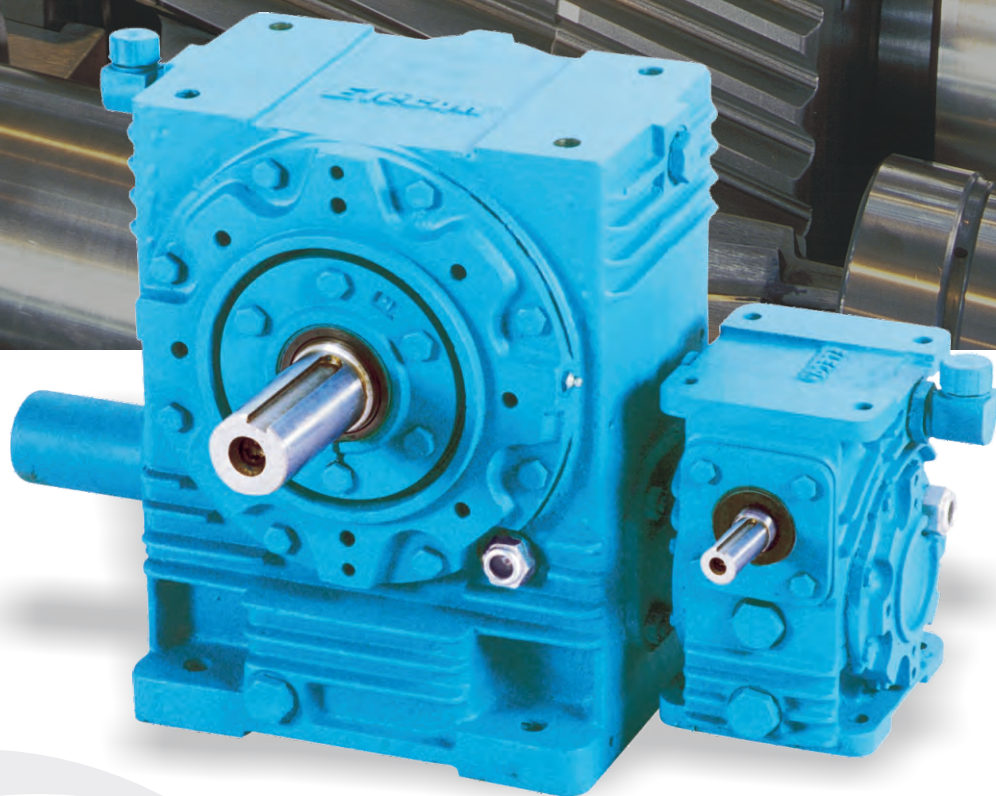
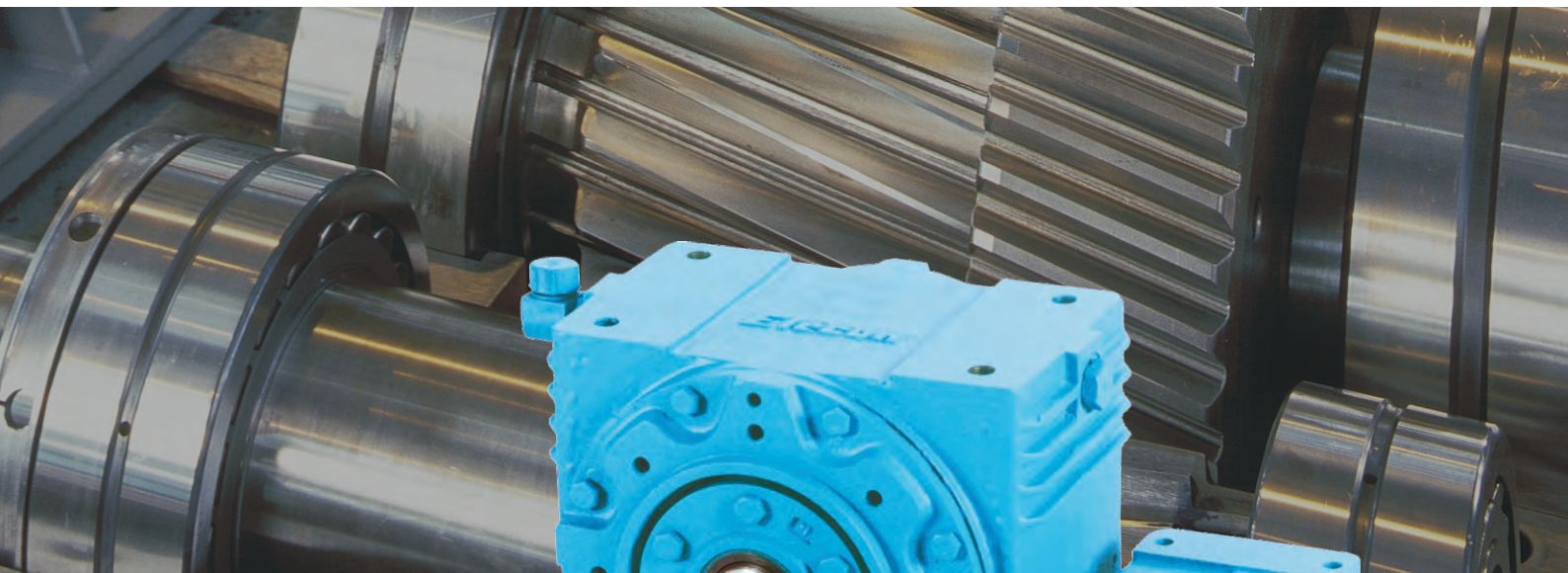

www.elecon.com

ELECON Double Reduction Worm Gear Units are constructed using two single reduction worm gear units. The primary worm gear unit is specially designed to mount integrally on a standard single worm gear unit which forms the secondary stage.

The complete gear unit becomes compact and rigid in arrangement for slow moving machinery. A wide range of ratio from 75:1 to 4900:1 is available.

These gear units are particularly suitable for high torque slow-speed drives. Worm gearing conforms to BS-721.

Explanation and use of ratings and service factors.

Gear unit selection is made by comparing actual loads with catalogue ratings. Catalogue ratings are based on a standard set of loading conditions whereas actual load conditions vary according to type of application. Service factors are therefore used to calculate an equivalent load to compare with catalogue ratings.

* Mechanical ratings and service factor (F_M)

Mechanical ratings measure capacity in terms of life and/or strength assuming 12 hr/day continuous running under uniform load conditions.

Catalogue ratings allow 100% overload at starting, breaking or momentarily during operations up to 12 hours per day.

TABLE NO.1 Mechanical service factor (F_M)

Prime mover	Duration of service hrs per day	Load classification - driven machine		
		Uniform	Moderate Shock	Heavy Shock
Electric motor, steam turbine or hydraulic motor	Under : 3	0.80	1.00	1.50
	3 to 10	1.00	1.25	1.75
	Over 10 to 24	1.25	1.50	2.00
Multi-cylinder internal combustion engine	Under : 3	1.00	1.25	1.75
	3 to 10	1.25	1.50	2.00
	Over 10 to 24	1.50	1.75	2.25
Single cylinder internal combustion engine	Under : 3	1.25	1.50	2.00
	3 to 10	1.50	1.75	2.25
	Over 10 to 24	1.75	2.00	2.50

- *For Units subject to frequent starts/stops and overloads, also applications where high inertia loads are involved e.g. crane travel drives, slewing motion etc. refer to Elecon.*

TABLE NO. 2 LOAD CLASSIFICATION BY APPLICATIONS

Driven Machine	Type of Load	Driven Machine	Type of Load
Agitators & mixers		Reciprocating	<i>H</i>
Pure Liquids, semi-liquids	<i>U</i>	Screw	<i>M</i>
Liquids and solids variable density	<i>M</i>	Food Industry	
Liquids with variable density	<i>M</i>	Beef slicer	<i>M</i>
Blowers		Cereal cooker	<i>U</i>
Centrifugal, vane	<i>U</i>	Laundry machines	
Lobe	<i>M</i>	Washers, tumblers	<i>M</i>
Brewing & distilling		Line shaft	<i>M</i>
Bottle machinery	<i>U</i>	Mills	
Brew kettle continuous duty	<i>U</i>	Hammers	<i>H</i>
Cookers, scale hopper	<i>M</i>	Ball kilns, pebbles	<i>M</i>
(frequent starts)		Rod tumbling barrels	<i>H</i>
Cane filling Machinery	<i>U</i>	Cement kilns	<i>M</i>
Cane knives	<i>M</i>	Dryers and coolers	<i>M</i>
Clarifiers•	<i>U</i>	Mixers	
Classifiers	<i>U</i>	Concrete mixers	<i>M</i>
Clay-working machinery		Sugar industry	
brick press, briquette machine	<i>H</i>	Cane knives	<i>M *</i>
Pug mill, clay-working machinery	<i>M</i>	Crushers	<i>M *</i>
Compressors		Mills	<i>H *</i>
Centrifugal	<i>U</i>	Oil industry	
Lobe	<i>M</i>	Chillers	<i>M</i>
Reciprocating multi-cylinder	<i>M</i>	Rotary kilns	<i>M</i>
Reciprocating single-cylinder	<i>H</i>	Paper mill	
Conveyors - Uniformly loaded or fed		Bleacher conveyor press, winder	
Apron, Belt, Bucket, Screw	<i>U</i>	Calendars, agitators, beater and pulper	<i>M</i>
Conveyors - Heavy Duty - Not Uniformly fed		Pumps	
Apron, Belt, Bucket, Screw	<i>M</i>	Centrifugal	<i>U</i>
Reciprocating and shaker	<i>M</i>	Reciprocating (three or more cylinders)	<i>M</i>
Cranes		Gear, lobe type	<i>U</i>
Main Hoist	<i>M</i>	Rubber & plastic industry	
Bridge Travel	*	Crackers	<i>H *</i>
Crushers		Fixing mills	<i>H *</i>
Ore, Stone	<i>H</i>	Laboratory equipment	<i>M</i>
Sugar	<i>M</i>	Refiners	<i>M *</i>
Elevators		Sheeters	<i>M *</i>
Bucket-uniform load	<i>U</i>	Tubers and strainers	<i>M *</i>
Bucket-heavy load	<i>M</i>	Warming mills	<i>M *</i>
Bucket-continuous load	<i>U</i>	Tyre and Tube press	<i>M *</i>
Centrifugal discharge	<i>U</i>	Sand Mullers	<i>M</i>
Gravity discharge	<i>U</i>	Screens	
Passenger lifts	*	Air washing	<i>U</i>
Fans		Rotary-stone / gravel	<i>M</i>
Centrifugal	<i>U</i>	Textile industry	
Induced draft	<i>M</i>	Batches	<i>M</i>
Large (mine, industrial, etc.)	<i>M</i>	Calendars	<i>M</i>
Light (small diameter)	<i>U</i>	Dyeing machinery	<i>M</i>
Cooling Towers	<i>H</i>	Spinners	<i>M</i>
Induced draft	*	Washers	<i>M</i>
forced draft	*	Winders	<i>M</i>
Feeders		Wire-drawing, Flattening machine	<i>M</i>
Apron	<i>M</i>	Wire Winding machine	<i>M</i>
Belt	<i>M</i>		
Disc.	<i>U</i>		

* Refer to Elecon

RATING CHART

INPUT SPEED 1500 RPM

RATIO	SPEED OUTPUT NOMINAL	CAPACITY	SIZE OF UNIT									
			2.25/40	2.25/50	3/60	3/70	4/80	4/90	5/105	5/120	6/140	7/170
75/1	20	INPUT POWER (kW)	2.55	3.00	7.10	8.00	13.40	14.60	21.00	22.20	38.00	51.00
		OUTPUT TORQUE (Nm)	962	1146	2746	3171	5311	5717	8624	9116	15605	21187
150/1	10	INPUT POWER (kW)	1.68	2.76	4.84	6.34	8.01	9.86	14.40	15.80	31.40	43.00
		OUTPUT TORQUE (Nm)	1169	2003	3374	4541	6043	7251	10452	11769	24289	34905
250/1	6	INPUT POWER (kW)	1.30	1.80	3.10	4.20	6.00	8.30	13.60	14.20	21.00	30.02
		OUTPUT TORQUE (Nm)	1676	2063	3553	4880	6972	9512	15586	16951	25737	37270
500/1	3	INPUT POWER (kW)	0.98	1.55	2.18	3.30	4.20	5.36	7.30	8.11	12.44	18.00
		OUTPUT TORQUE (Nm)	1747	3158	4511	6933	9359	10579	15570	17814	27720	41256
750/1	2	INPUT POWER (kW)	0.75	0.86	1.80	2.17	3.00	4.12	4.60	6.60	10.00	15.00
		OUTPUT TORQUE (Nm)	1934	2341	4727	6217	9455	10820	13838	17964	30560	46556
1000/1	1.50	INPUT POWER (kW)	0.51	0.80	1.46	2.20	2.35	3.10	4.21	5.87	9.20	11.00
		OUTPUT TORQUE (Nm)	1656	2649	4834	7984	8977	10658	14206	19434	34558	45522
1500/1	1	INPUT POWER (kW)	0.36	0.65	0.92	1.16	2.12	2.70	2.83	4.00	6.06	8.50
		OUTPUT TORQUE (Nm)	1822	3166	4569	5317	10933	11861	14054	19100	31830	45458
2000/1	0.75	INPUT POWER (kW)	0.41	0.52	0.84	1.06	1.43	1.80	2.00	3.40	5.64	7.80
		OUTPUT TORQUE (Nm)	2610	2980	4706	6614	9286	10314	12224	20348	35908	51646
2500/1	0.60	INPUT POWER (kW)	0.21	0.40	0.68	0.88	1.18	1.32	1.87	2.80	4.25	6.25
		OUTPUT TORQUE (Nm)	1404	2547	4762	6023	9391	9455	12799	20055	32470	51729
3000/1	0.50	INPUT POWER (kW)	0.26	0.35	0.58	0.80	0.93	1.16	1.72	2.50	3.72	5.20
		OUTPUT TORQUE (Nm)	1837	2540	4431	6112	8171	8641	13798	19100	32684	48667
4200/1	0.36	INPUT POWER (kW)	0.14	0.28	0.45	0.76	0.68	0.81	1.12	1.75	2.91	4.00
		OUTPUT TORQUE (Nm)	1374	2823	4178	7661	7396	8810	11290	18569	33194	47750
4900/1	0.30	INPUT POWER (kW)	0.10	0.18	0.30	0.50	0.58	0.70	0.73	1.07	2.00	3.00
		OUTPUT TORQUE (Nm)	1114	1719	3152	5093	7201	8691	9295	13625	25467	42020

- The Rating are based on service factor of 1, continuously transmitted for 12 hours/day with normal overload of 100% momentarily for 15 seconds, 40% for 30 minutes, 25% for 2 hours.

RATING CHART

INPUT SPEED 1000 RPM

RATIO	SPEED OUTPUT NOMINAL	CAPACITY	SIZE OF UNIT									
			2.25/40	2.25/50	3/60	3/70	4/80	4/90	5/105	5/120	6/140	7/170
75/1	13.30	INPUT POWER (kW)	2.00	2.80	5.00	6.12	10.60	11.30	16.10	20.00	31.70	41.50
		OUTPUT TORQUE (Nm)	1106	1548	2836	3516	6317	6653	9480	12207	19348	25627
150/1	6.67	INPUT POWER (kW)	1.50	2.00	3.80	5.10	6.43	7.31	11.20	15.00	22.00	32.62
		OUTPUT TORQUE (Nm)	1589	1976	3809	5404	6993	7846	11867	16537	23939	39232
250/1	4	INPUT POWER (kW)	1.10	1.60	2.40	3.20	4.40	5.64	7.73	10.00	16.00	23.10
		OUTPUT TORQUE (Nm)	1812	2598	3954	5424	7461	10104	12917	17668	28650	40812
500/1	2	INPUT POWER (kW)	0.76	1.10	1.80	2.50	3.46	4.10	4.80	5.60	10.70	12.50
		OUTPUT TORQUE (Nm)	1996	2941	5415	7521	10574	12725	13752	17916	34743	41781
750/1	1.33	INPUT POWER (kW)	0.50	0.76	1.34	1.80	2.14	3.00	4.00	5.00	6.60	8.28
		OUTPUT TORQUE (Nm)	1903	2892	5388	6984	9527	11848	16946	21182	30340	39240
1000/1	1	INPUT POWER (kW)	0.43	0.70	0.88	1.32	1.44	2.15	3.52	4.12	6.00	7.20
		OUTPUT TORQUE (Nm)	2012	3276	4456	6431	7426	10256	17486	22034	33234	43319
1500/1	0.66	INPUT POWER (kW)	0.30	0.48	0.72	0.82	1.10	1.34	2.24	3.23	4.00	5.44
		OUTPUT TORQUE (Nm)	1997	3056	5001	5458	8595	9293	15266	21971	31255	44104
2000/1	0.50	INPUT POWER (kW)	0.25	0.43	0.66	0.80	0.92	1.20	2.00	2.60	3.70	4.30
		OUTPUT TORQUE (Nm)	1910	3285	5547	6579	7907	10976	17572	23340	34602	41886
2500/1	0.40	INPUT POWER (kW)	0.18	0.38	0.48	0.67	0.87	0.95	1.57	2.20	3.16	3.82
		OUTPUT TORQUE (Nm)	1681	3448	4813	6549	8932	9306	15338	22061	33952	43743
3000/1	0.33	INPUT POWER (kW)	0.12	0.22	0.37	0.55	0.66	0.81	1.36	1.94	2.80	3.30
		OUTPUT TORQUE (Nm)	1250	2292	3745	6318	8595	9375	15300	22418	34024	43930
4200/1	0.24	INPUT POWER (kW)	0.10	0.18	0.28	0.44	0.50	0.60	0.95	1.32	2.04	2.41
		OUTPUT TORQUE (Nm)	1194	2149	3788	6130	8953	9766	13241	18390	30881	42193
4900/1	0.20	INPUT POWER (kW)	0.08	0.15	0.21	0.35	0.46	0.50	0.80	1.14	1.73	2.05
		OUTPUT TORQUE (Nm)	1107	2006	3109	6557	8347	8386	12988	17486	29810	41039

- The Rating are based on service factor of 1, continuously transmitted for 12 hours/day with normal overload of 100% momentarily for 15 seconds, 40% for 30 minutes, 25% for 2 hours.

RATING CHART

INPUT SPEED 750 RPM

RATIO	SPEED OUTPUT NOMINAL	CAPACITY	SIZE OF UNIT									
			2.25/40	2.25/50	3/60	3/70	4/80	4/90	5/105	5/120	6/140	7/170
75/1	10	INPUT POWER (kW)	1.85	2.64	4.14	5.12	9.20	10.50	14.70	16.40	26.00	31.60
		OUTPUT TORQUE (Nm)	1325	1967	3082	3912	7556	8022	11231	12843	20609	25651
150/1	5	INPUT POWER (kW)	1.30	1.86	3.25	3.52	5.10	6.00	8.85	12.30	15.80	22.50
		OUTPUT TORQUE (Nm)	1738	2483	4345	4909	7695	8595	12678	17620	22634	34810
250/1	3	INPUT POWER (kW)	0.80	1.40	2.10	3.00	3.45	4.60	6.30	8.20	12.76	18.80
		OUTPUT TORQUE (Nm)	1655	2941	4479	6494	7578	10104	14045	18794	29246	46680
500/1	1.5	INPUT POWER (kW)	0.55	0.92	1.40	2.10	3.00	3.85	4.10	5.55	9.00	10.10
		OUTPUT TORQUE (Nm)	1821	3264	5615	7888	10887	13481	16445	22968	37818	43726
750/1	1	INPUT POWER (kW)	0.40	0.62	1.10	1.45	1.86	2.40	3.20	4.00	5.10	7.00
		OUTPUT TORQUE (Nm)	1872	3079	5883	8309	9770	13752	17725	22920	29223	42784
1000/1	0.75	INPUT POWER (kW)	0.35	0.60	0.80	1.20	1.60	2.00	2.80	3.20	4.60	6.20
		OUTPUT TORQUE (Nm)	2050	3811	5297	7793	10798	12733	19609	22411	32801	43421
1500/1	0.5	INPUT POWER (kW)	0.24	0.44	0.60	0.80	0.97	1.25	1.75	2.40	3.30	4.00
		OUTPUT TORQUE (Nm)	1879	3531	4928	6876	8323	10983	15545	22003	32776	42020
2000/1	0.37	INPUT POWER (kW)	0.20	0.31	0.53	0.68	0.93	1.00	1.58	2.25	2.80	3.40
		OUTPUT TORQUE (Nm)	1910	3201	5609	7723	10597	11357	18302	26174	33244	45634
2500/1	0.3	INPUT POWER (kW)	0.16	0.28	0.40	0.56	0.75	0.78	1.21	1.72	2.43	3.00
		OUTPUT TORQUE (Nm)	1783	3209	4792	6774	9528	10475	15356	22449	34036	44885
3000/1	0.25	INPUT POWER (kW)	0.14	0.20	0.31	0.48	0.65	0.73	1.06	1.50	2.23	2.80
		OUTPUT TORQUE (Nm)	1765	2598	4237	6601	9435	10712	15387	22920	34030	48132
4200/1	0.17	INPUT POWER (kW)	0.12	0.18	0.27	0.35	0.56	0.62	0.70	0.97	1.60	2.00
		OUTPUT TORQUE (Nm)	1685	2769	4599	5899	9495	10385	12977	19072	32358	43818
4900/1	0.15	INPUT POWER (kW)	0.10	0.12	0.17	0.23	0.42	0.46	0.62	0.80	1.38	1.70
		OUTPUT TORQUE (Nm)	1592	2275	3195	4393	8070	8786	11842	15789	27277	44376

- The Rating are based on service factor of 1, continuously transmitted for 12 hours/day with normal overload of 100% momentarily for 15 seconds, 40% for 30 minutes, 25% for 2 hours.

SNU-UD

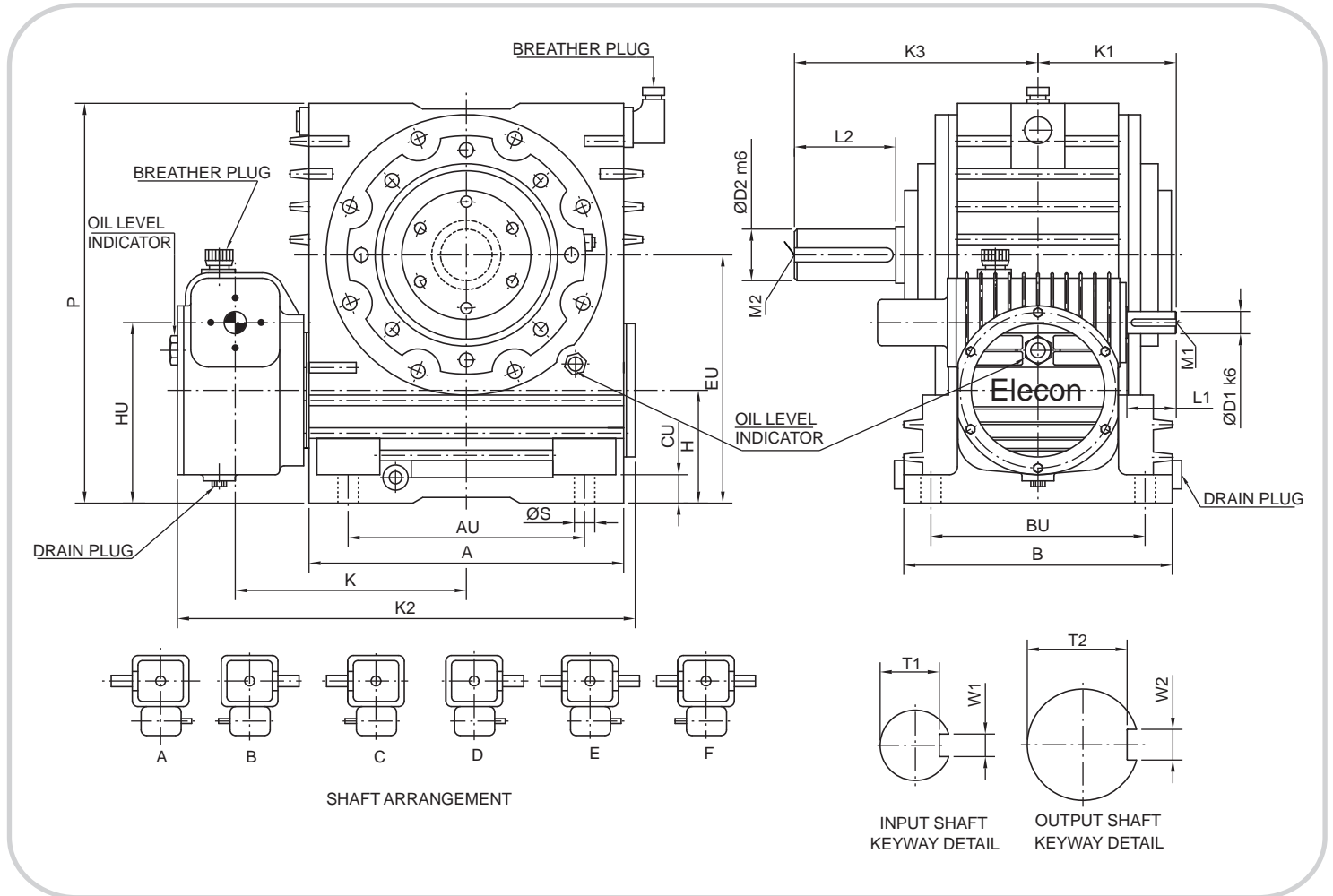

SIZE	A	AU	B	BU	CU	S	HU	H	EU	P	K	K1	K2	K3	D1	L1	M1	T1	W1	D2	L2	M2	T2	W2
2 1/4/40	250	180	200	160	25	18	165.15	108	209.6	325	215.5	142	425	215	22	50	-	18.5	6	45	90	M16	39.5	14
2 1/4/50	300	220	252	200	30	18	175.15	118	245	385	242.5	142	480	235	22	50	-	18.5	6	50	100	M16	44.5	14
3/60	354	266	300	241	32	23	203.2	127	279.4	450	270	155	540	274	25	50	M8	21	8	58	114	M20	52	16
3/70	400	306	340	266	36	23	222.2	146	323.8	524	273	155	560	287	25	50	M8	21	8	65	130	M20	58	18
4/80	440	343	340	266	40	27	247.6	146	349.2	574	294	230	626	312	32	65	M12	27	10	70	140	M20	62.5	20
4/90	490	390	344	282	40	27	255.6	154	382.6	635	320	230	683	325	32	65	M12	27	10	75	145	M20	67.5	20
5/105	590	432	430	330	50	33	299	172	438.7	720	380	260	792	352	35	70	M12	30	10	80	150	M20	71	22

Key & keyways as per IS 2048, Shaft limits: up to Ø58 – k6 and above Ø58 – m6.

SNU-OD

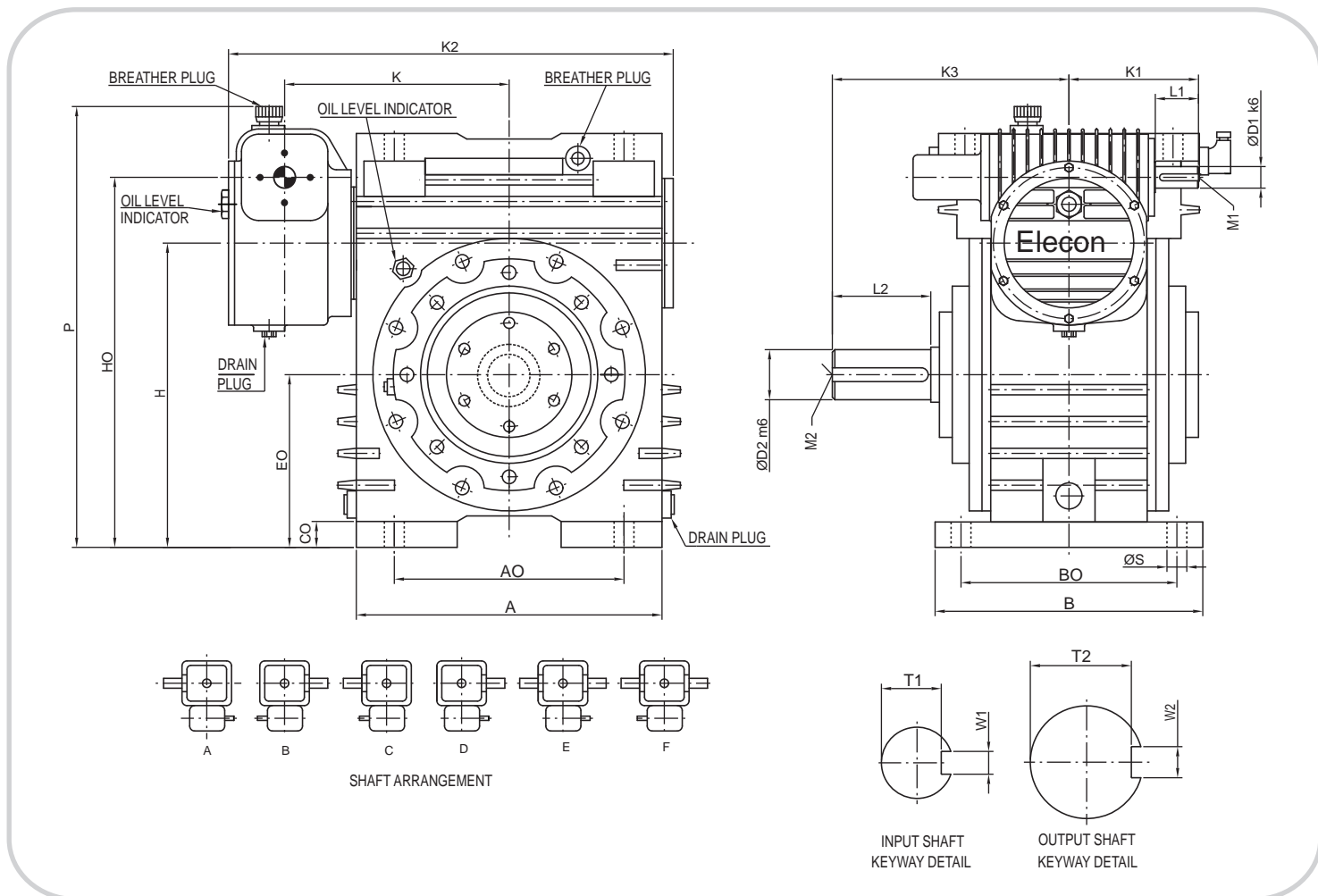

SIZE	A	AO	B	BO	CO	S	EO	H	HO	P	K	K1	K2	K3	D1	L1	M1	T1	W1	D2	L2	M2	T2	W2
2 1/4/40	250	180	240	200	25	18	140	241.6	298.75	380	215.5	142	425	215	22	50	-	18.5	6	45	90	M16	39.5	14
2 1/4/50	300	220	270	230	25	18	165	292	349.15	430	242.5	142	480	235	22	50	-	18.5	6	50	100	M16	44.5	14
3/60	354	266	310	250	30	23	200	352.4	428.6	510	270	155	540	274	25	50	M8	21	8	58	114	M20	52	16
3/70	400	306	340	266	44	23	244	421.8	498	580	273	155	560	287	25	50	M8	21	8	65	130	M20	58	18
4/80	440	343	340	266	44	27	269	472.2	573.8	665	294	230	626	312	32	65	M12	27	10	70	140	M20	62.5	20
4/90	490	390	414	340	44	27	296	524.6	626.2	718	320	230	683	325	32	65	M12	27	10	75	145	M20	67.5	20
5/105	590	432	484	400	50	33	331	597.7	724.7	825	380	260	792	352	35	70	M12	30	10	80	150	M20	71	22

Key & keyways as per IS 2048, Shaft limits: up to Ø58 – k6 and above Ø58 – m6.

SNU-VD

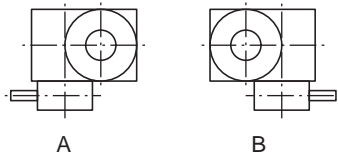
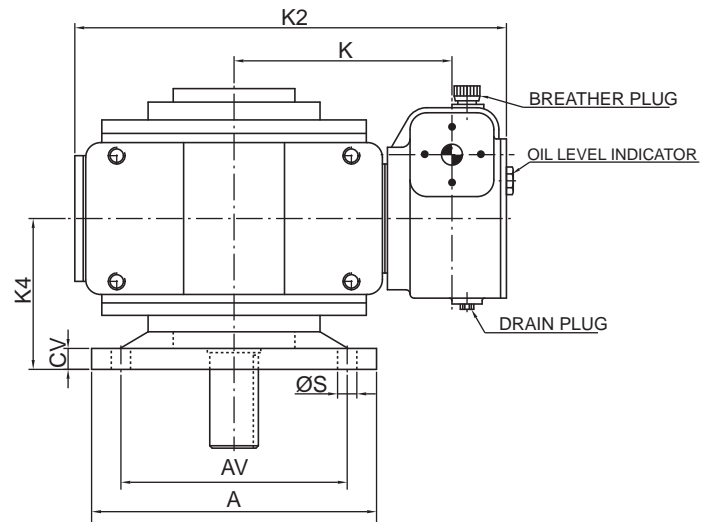
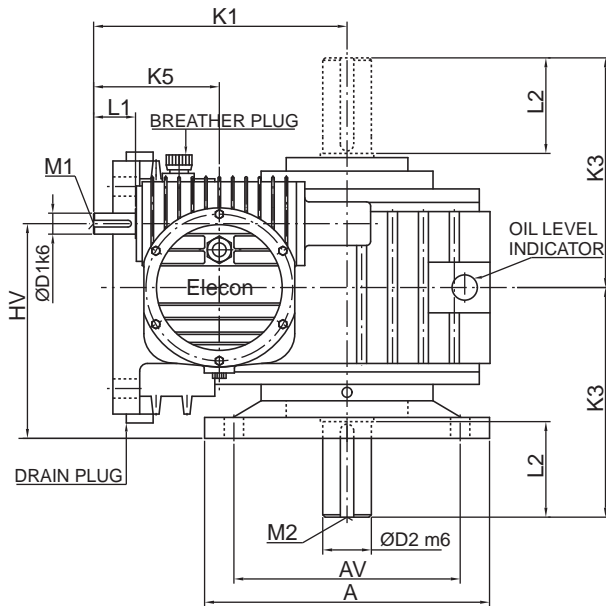

SHAFT ARRANGEMENT

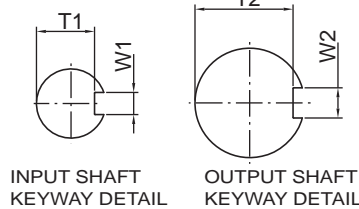

INPUT SHAFT KEYWAY DETAIL

OUTPUT SHAFT KEYWAY DETAIL

SIZE	A	AV	HV	CV	S	K	K1	K2	K3	K4	K5	D1	L1	M1	T1	W1	D2	L2	M2	T2	W2
2 1/4/40	280	235	197.15	20	18	215.5	243.6	425	215	140	142	22	50	-	18.5	6	45	90	M16	39.5	14
2 1/4/50	320	260	222.15	22	18	242.5	269	480	235	185	142	22	50	-	18.5	6	50	100	M16	44.5	14
3/60	340	270	256.20	25	23	270	302.4	540	274	180	155	25	50	M8	21	8	58	114	M20	52	16
3/70	400	320	276.2	40	27	273	307.4	560	287	200	155	25	50	M8	21	8	65	130	M20	58	18
4/80	400	360	312.6	40	27	294	432.2	626	312	220	230	32	65	M12	27	10	70	140	M20	62.5	20
4/90	490	410	341.6	40	27	320	457.6	683	325	240	230	32	65	M12	27	10	75	145	M20	67.5	20
5/105	560	460	387	40	33	380	526.7	792	352	260	260	35	70	M12	30	10	80	150	M20	71	22

Key & keyways as per IS 2048, Shaft limits: up to Ø58 – k6 and above Ø58 – m6.

SNU-SMD

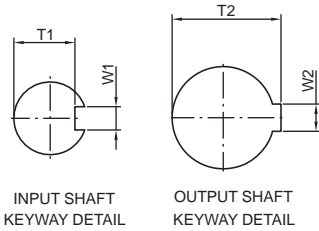
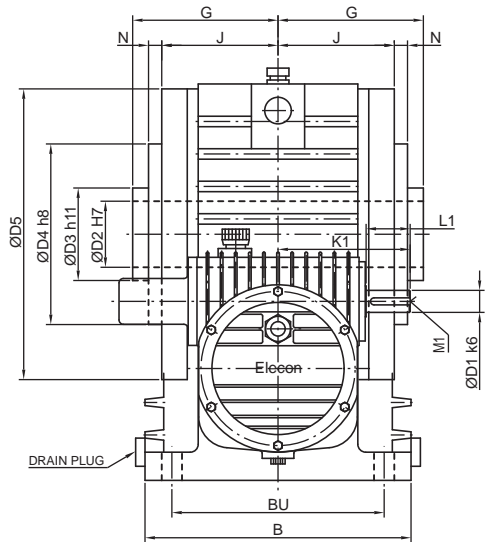
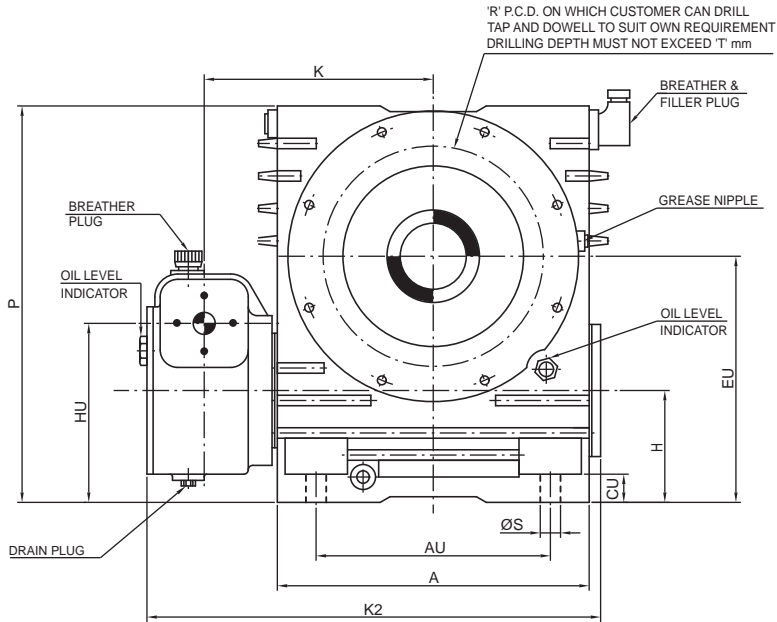

B BREATHING PLUG
L OIL LEVEL INDICATOR
G GREASE NIPPLE
D DRAIN PLUG

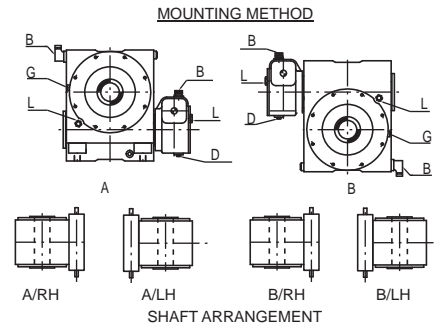

SIZE	A	AU	B	BU	CU	S	HU	H	EU	P	K	K1	K2	G	J	N	D1	L1	M1	T1	W1	D2	T2	W2	D3	D4	D5	R	T
2 1/4/40	250	180	200	160	25	18	165.15	108	209.6	325	215.5	142	425	115	95	6	22	50	-	18.5	6	65	69.4	18	95	146	222	165	20
2 1/4/50	300	220	252	200	30	18	175.15	118	245	385	242.5	142	480	145	115	15	22	50	-	18.5	6	70	75.1	20	105	195	272	210	20
3/60	354	266	300	241	32	23	203.2	127	279.4	450	270	155	540	165	132	15	25	50	M8	21	8	75	80.1	20	105	205	330	250	20
3/70	400	306	340	266	36	23	222.2	146	323.8	524	273	155	560	160	132	8	25	50	M8	21	8	80	85.6	22	120	224	390	280	20
4/80	440	343	340	266	40	27	247.6	146	349.2	574	294	230	626	180	148	8	32	65	M12	27	10	90	95.6	25	130	263	445	318	20
4/90	490	390	344	282	40	27	255.6	154	382.6	635	320	230	683	190	157	8	32	65	M12	27	10	95	100.6	25	140	266	492	330	20
5/105	590	432	430	330	50	33	299	172	438.7	720	380	260	792	205	180	8	35	70	M12	30	10	100	106.6	28	152	292	540	380	20

Key & keyways as per IS 2048, Shaft limits: up to Ø58 – k6 and above Ø58 – m6.

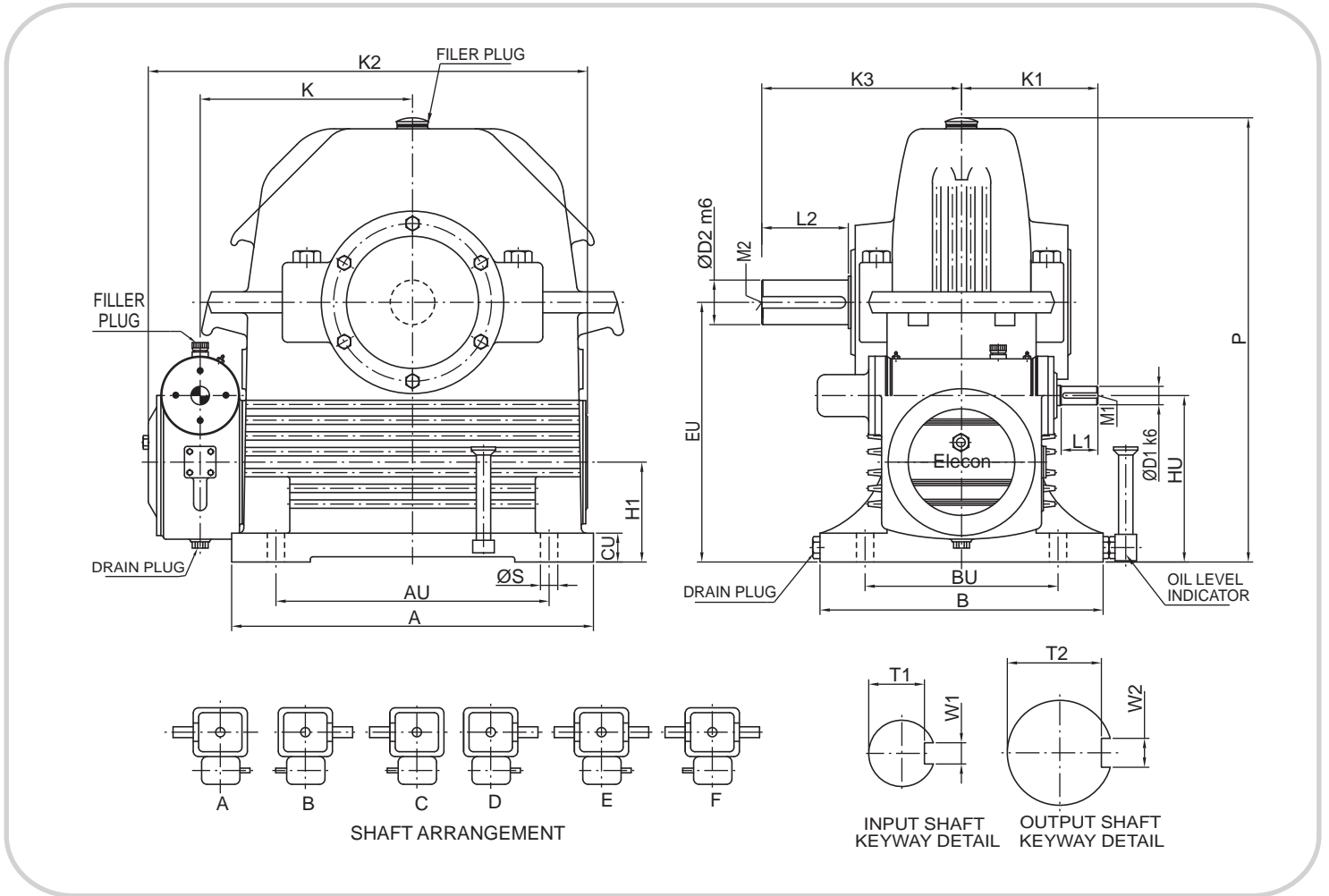

SIZE	A	AU	B	BU	CU	S	HU	H1	EU	P	K	K1	K2	K3	D1	L1	M1	T1	W1	D2	L2	M2	T2	W2
5/120	690	521	540	368	55	33	317.5	190.5	495.3	860	405	260	855	381	35	70	M12	30	10	85	165	M20	76	22
6/140	820	597	560	432	65	33	367.4	216	571.6	988	480	279	1002	420	38	76	M12	33	10	110	200	M24	100	28
7/170	920	762	600	508	75	33	431.8	254	685.8	1181	670	311	1351	525	40	82	M16	35	12	135	215	M30	123	36

Key & keyways as per IS 2048, Shaft limits: up to $\varnothing 58 - k6$ and above $\varnothing 58 - m6$.
 FOR SIZE 7/170 - 6 HOLE DIA.'S'

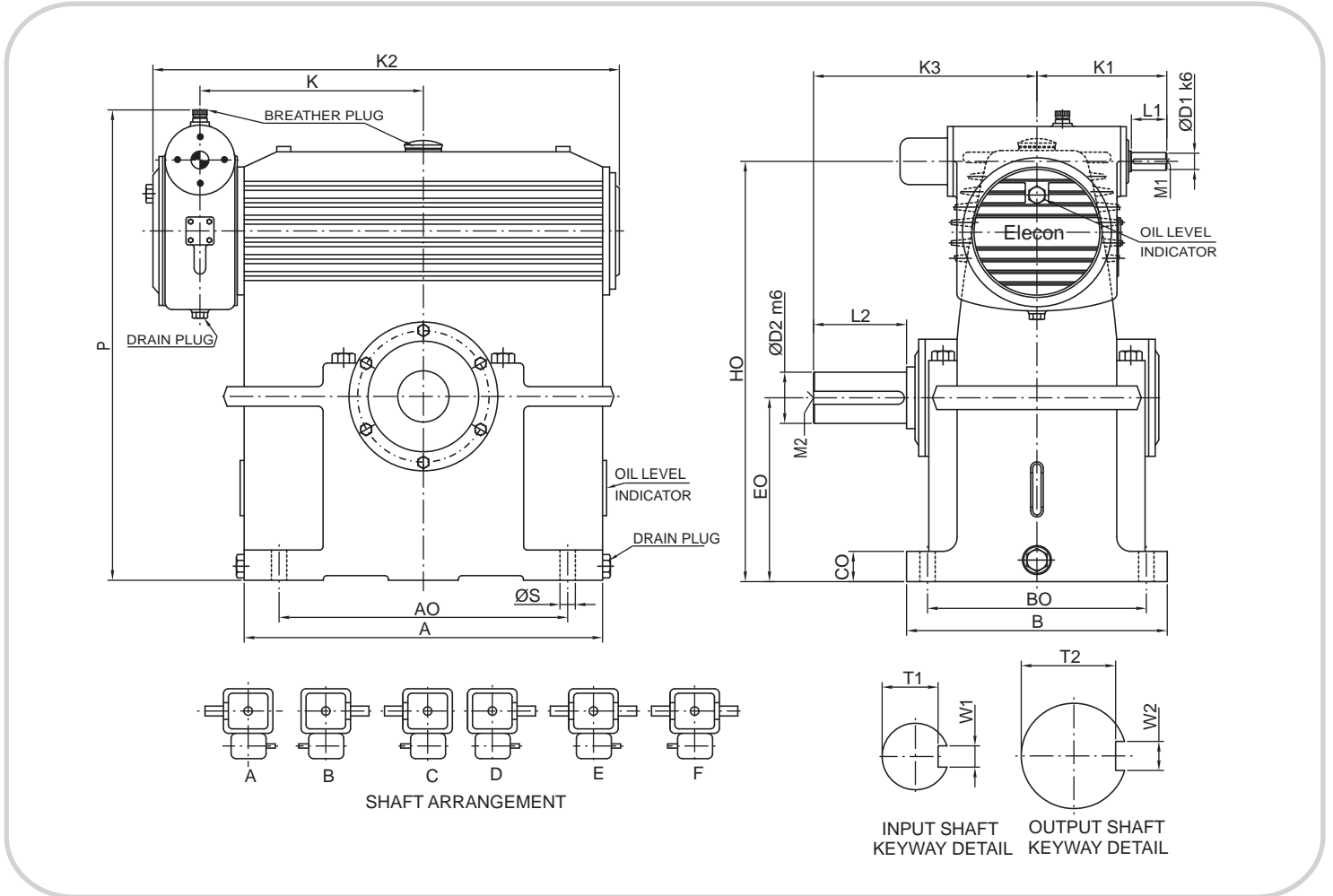

SIZE	A	AO	B	BO	CO	S	EO	HO	P	K	K1	K2	K3	D1	L1	M1	T1	W1	D2	L2	M2	T2	W2
5/120	630	530	540	440	55	33	330	761.8	863	405	260	855	381	35	70	M12	30	10	85	165	M20	76	22
6/140	770	620	560	470	65	33	395	903	1011	480	279	1002	480	38	76	M12	33	10	110	200	M24	100	28
7/170	920	750	600	510	75	33	460	1069.6	1200	670	311	1351	525	40	82	M16	35	12	135	215	M30	123	36

Key & keyways as per IS 2048, Shaft limits: up to Ø58 – k6 and above Ø58 – m6.
 FOR SIZE 7/170 - 6 HOLE DIA.'S'

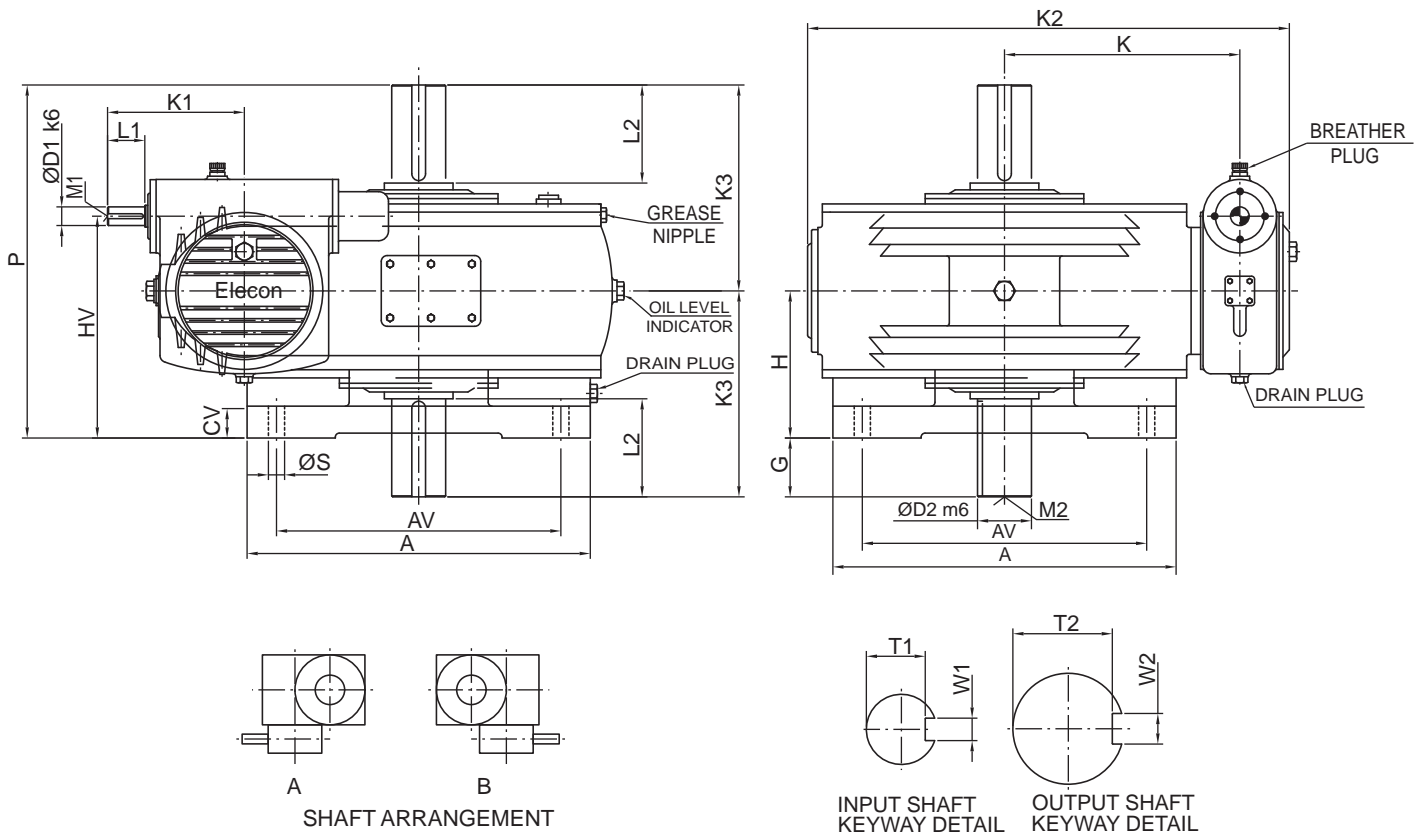

SIZE	A	AV	HV	CV	S	P	G	H	K	K1	K2	K3	D1	L1	M1	T1	W1	D2	L2	M2	T2	W2
5/120	620	500	407.00	60	33	661	101	280	405	260	855	381	35	70	M12	30	10	85	165	M20	76	22
6/140	700	580	452.40	65	33	720	120	300	480	279	1002	420	38	76	M12	33	10	110	200	M24	100	28
7/170	1000	800	522.80	75	40	870	180	345	670	311	1351	525	40	82	M16	35	12	135	215	M30	123	36

Key & keyways as per IS 2048, Shaft limits: up to $\text{Ø}58 - k6$ and above $\text{Ø}58 - m6$.

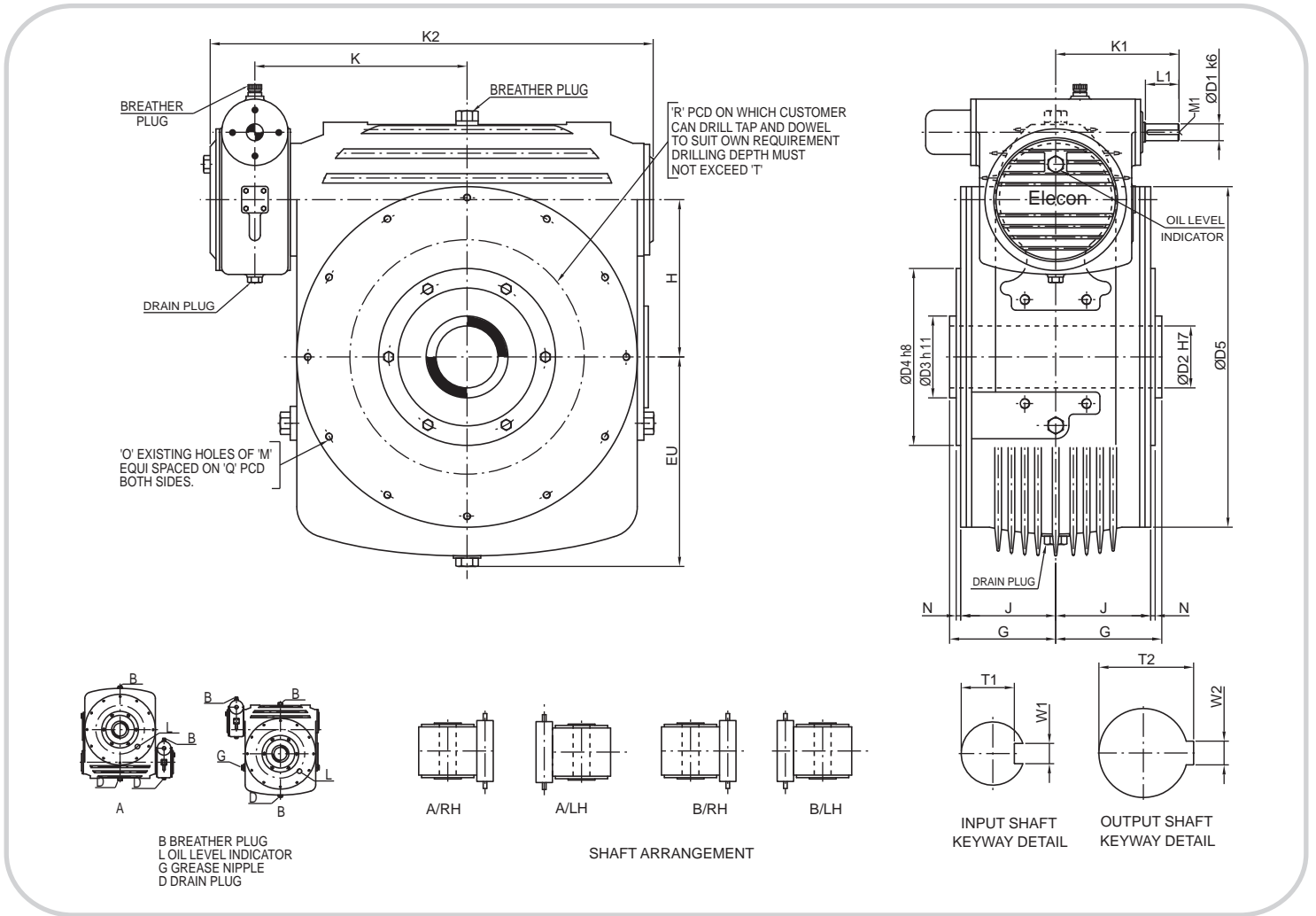

SIZE	EU	H	K	K1	K2	G	J	N	D1	L1	M1	T1	W1	D2	T2	W2	D3	D4	D5	R	T	O	M	Q
5/120	380	304.8	405	260	855	220	190	10	35	70	M12	30	10	110	116.6	28	180	360	640	450	25	12	M12	605
6/140	450	355.6	480	279	1002	240	215	10	38	76	M12	33	10	140	148.7	36	185	400	770	530	21	12	M16	720

Key & keyways as per IS 2048, Shaft limits: up to Ø58 – k6 and above Ø58 – m6.

ACTUAL RATIO

GEAR SIZE	2 1/4 /40	2 1/4 /50	3/60	3/70	4/80	4/90	5/105	5/120	6/140	7/170
GEAR RATIO										
75:1	69.6	69.6	70.08	70.89	70.89	70.89	70.89	70.89	71.24	75.815
150:1	152.25	152.25	140.17	145	141.78	141.38	142.58	142.58	148.14	151.1
250:1	262.5	262.5	241.67	236.83	236.83	236.83	236.83	236.83	236.83	246.5
500:1	525	525	500	490	477.75	477.75	477.75	477.75	477.75	497.25
750:1	720	725	750	725	725	725	725	725	710.5	718.67
1000:1	960	960	1000	1000	1000	1000	1000	1000	975	980
1500:1	1450	1450	1500	1500	1500	1500	1500	1500	1470	1470
2000:1	2000	2000	2000	2000	2000	2000	2000	2000	1950	2000
2500:1	2500	2500	2500	2500	2500	2500	2500	2500	2450	2450
3000:1	3050	3050	3000	3000	3000	3000	3000	3000	2940	2940
4200:1	4200	4200	4200	4200	4140	4140	4260	4260	4270	4260
4900:1	4830	4970	4900	4970	4830	4899	4970	4970	4830	5041

SHIPPING SPECIFICATION & OIL CAPACITY.

GEAR SIZE		2 1/4 /40	2 1/4 /50	3/60	3/70	4/80	4/90	5/105	5/120	6/140	7/170
		SNU-UD						SFUD			
Net Weight (Kgs)		79	109	184	200	270	350	530	720	1100	1350
Gross Weight (Kgs)		110	130	220	240	320	410	615	950	1190	1405
Approx Oil Capacity (Lts)	1 st Stage	0.7	0.7	2.2	2.5	3.5	3.5	4.5	4.5	6.5	6
	2 nd Stage	2.5	4	5	9	11	15	20	25	36	60
		SNU-OD						SFOD			
Net Weight (Kgs)		86	119	195	210	290	385	550	745	1070	1300
Gross Weight (Kgs)		125	150	250	250	340	440	630	958	1220	1500
Approx Oil Capacity (Lts)	1 st Stage	0.8	0.8	2	2	3.5	3.5	4.5	4.5	6.5	6
	2 nd Stage	4.1	8	13.5	14.5	15.5	17	22	27	38	95
		SNU-VD						SFVD			
Net Weight (Kgs)		87	119	195	205	300	350	520	720	1000	1700
Gross Weight (Kgs)		110	150	250	260	360	410	615	950	1090	1720
Approx Oil Capacity (Lts)	1 st Stage	0.7	0.7	2.2	2.2	3.5	3.5	4.5	4.5	6.5	6
	2 nd Stage	3.1	5.7	8.5	9.9	10	11	20	29	43	106
		SNU-SMD						SSMD			
Net Weight (Kgs)		78	124	189	232	324	402	570	885	1445	-
Gross Weight (Kgs)		110	150	225	280	380	470	685	1130	1850	-
Approx Oil Capacity (Lts)	1 st Stage	0.8	0.8	2	2	3.5	3.5	4.5	4.5	6.5	-
	2 nd Stage	2.5	4	6	9.5	12.6	17.6	24.5	13.75	17	-

RECOMMENDED LUBRICANTS

I MINERAL OIL :

Brand	Grade
International Brands	
British Petroleum	CS 320 or GR-XP320
Castrol	Alpha Zn 320 or Alpha Sp-320 or Tribol 1100/320 TGQA
Caltex	Meropa 320
Esso Petroleum	Teresso 320 or Spartan 320
Fuchs	Renolin CKC 320
Mobil Oil Co.	Mobil DTE Oil AA or Mobilgear 632
Shell Co.	Vitera Oil 320 or Omela 320
Indian Brands	
Bharat Petroleum	Cabol 320
Balmer Lawrie Fuchs	Renolin CKC 320
Castrol	Alpha Zn 320 or Alpha Sp-320 or Tribol 1100/320 TGQA
Gulf	Gulf harmony 320 or Gulf EP 320
Hindustan Petroleum	Enklo 320 or Parthan EP 320
Indian Oil	Servomesh SP 320 or Servosystem 320
Veedol	Avalon 320

Recommended Grease : For low speed of operations.

Brand	Grade
Castrol	EPL 2
Indian Oil	SERVOGEM EP 2

II POLYGLYCOL BASED SYNTHETIC LUBRICANT

- í USE OF POLYGLYCOL BASED SYNTHETIC LUBRICANT IS ALSO ADVISABLE TO IMPROVE THE TRANSMITTING CAPACITY (RATING) OF GEAR UNITS MIN. 20% AS COMPARED WITH USE OF MINERAL OIL AT SAME WORKING TEMPERATURE. THIS GEAR OIL SHOWS EXCELLENT NON-AGEING STABILITY WITH FAVOURABLE INFLUENCE ON EFFICIENCY.

Approved Synthetic Lubricants

Brand	Grade
Castrol	Tribol 800-220
Fuchs	Renolin PG 220

Special Note: Synthetic Lubricants must not be mixed with any other type of oil. The gear unit must be flushed while changing to or from this lubricant.

OPTIONAL STANDARD FEATURES

1. SPRAG Holdbacks for Non-reversible Drives

ELECON gear unit can be supplied, fitted with sprag holdback for non-reversible drives it is essential that the load or driven mechanism is prevented from running backwards after the driving motor is stripped e.g. inclined conveyors, elevator, winches etc.

The sprag holdback is incorporated on the fan end side of the high speed shaft. Visually and dimensionally the ELECON unit is unchanged. The hold back can be provided for either direction of rotation and the same should be specified when ordering.

2. Base Frame

Fabricated steel base frames are also supplied when requires.

3. Steel Gearcases

ELECON gear unit can be supplied with cast or fabricated steel cases for heavy duty application when loadings on the housings are in excess of the capacities of standard cast iron cases.

4. Wormwheel construction

Standard worm wheel comprise phosphorous bronze rims continuous welded to cast iron centres, where the duties demand rims are welded to steel centres.

5. Slow speed shafts

ELECON gear unit can be supplied with special slow speed shafts where required, These include units with special single extension, double extended shafts to the standard dimensions listed in this catalogue or special double ended extension. Additionally single or double ended shaft can be supplied in high tensile steel to heavy duty applications.

General ELECON gear units will operate safely provided that they are selected, installed, used and maintained properly. As with any equipment consisting of rotating shafts and transmitting power, adequate guarding is necessary to eliminate the possibility of physical contact with rotating shafts or couplings.

Potential Hazards The following points should be noted and brought to attention to the persons involved in the installation, use and maintenance of equipment.

1. For lifting of gear unit eye-bolts or lifting points (on larger units) should be used.
2. Check the grade and quantity of lubrication before commissioning. Read and carry out all instructions on lubricant plate and in the installation and maintenance manual literature.
3. Installation must be performed in accordance with the manufacturer's instruction and be undertaken by suitably qualified personnel.
4. Ensure the proper maintenance of gearboxes in operation. **USE ONLY ELECON SPARES FOR GEARBOXES.**
5. The oil level should be examined periodically, if required the oil should be filled again.
6. The operating speeds, transmitting powers, generated torques or the external loads must not exceed the design values.
7. The driving and the driven equipment must be correctly selected to ensure that the complete installation of the machinery will perform satisfactorily e.g. avoiding system critical speeds, system torsional vibration etc.

Any other required information or clarification can be obtained by writing to :

ELECON ENGINEERING CO. LTD.

POST BOX # 6, VALLABH VIDYANAGAR 388 120, GUJARAT, INDIA

TEL.: +91-2692-236513, 236520, 232890 FAX : +91-2692-236527

E-MAIL : infogear@elecon.com

Web Site : <http://www.elecon.com>

As improvement in designing are continuously being made, the details and dimensions are subject to alteration without notice.